



The product shown may differ from standard configuration.

## PRIMO® XXM

Standard Seat with Mechanical Suspension



# PRIMO® XXM

## Technical data

### Standard seat

The Primo XXM has an easy-to-use lever for optimally setting the suspension to the driver's weight within the range between 45 and 170 kg. Especially when a vehicle is used by multiple drivers, it's important for unpracticed users to be able to quickly and intuitively perform this important setting. The extra-high backrest, in conjunction with a lumbar support, bolsters the back and ensures an even more comfortable ride. The Primo XXM is equipped with an operator presence switch as well as a duosensitive ELR-belt system as standard.



Mechanical suspension



Mechanical lumbar support



Manual weight adjustment

### Features

Features	PRIMO® XXM	PRIMO® XXM	PRIMO® XXM
<b>ARTICLE NO.</b>			
Fabric	1293475		
Imitation leather	1106231		
<b>STANDARD FEATURES</b>			
Shock absorber, nonadjustable	●		
Suspension, mechanical	●		
Suspension stroke, 80 mm	●		
<b>1</b> Weight adjustment, manual, 45-170 kg	●		
<b>2</b> Fore/aft adjustment, 210 mm	●		
<b>3</b> Lumbar support, mechanical	●		
<b>4</b> Adjustable backrest angle	●		
		<b>5</b> ELR-belt system, duosensitive	●
		Seat cushion width	450 mm
		Operator presence switch (OPS)	●
		<b>OPTIONAL FEATURES</b>	
		<b>6</b> Document box	○
		<b>7</b> Armrests, adjustable angle, 60 mm x 320 mm	○
		Fore/aft isolator*	○
		<b>8</b> Seat heating	○

\* Fore/aft isolator not for earth-moving machinery

### Measurements (installation dimensions)

● STANDARD FEATURES ○ OPTIONAL FEATURES

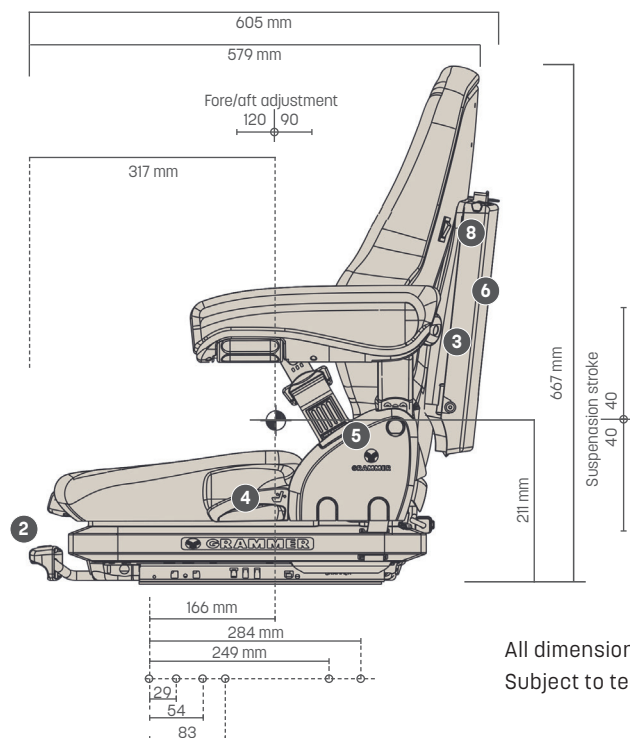
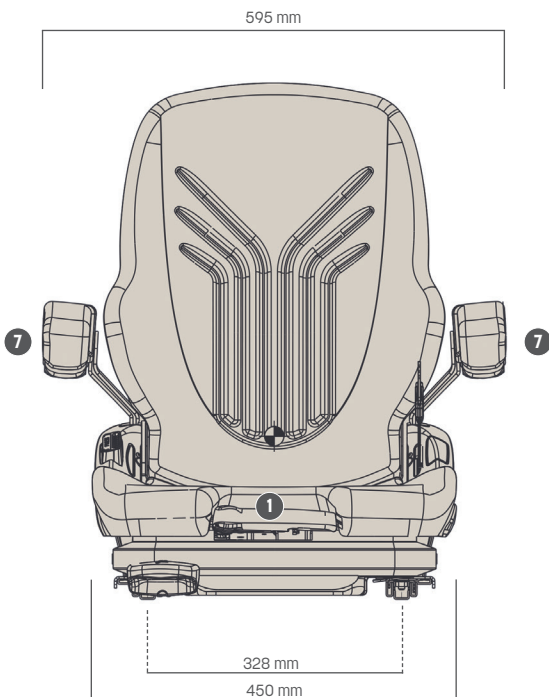

All dimensions in mm.  
Subject to technical changes.